

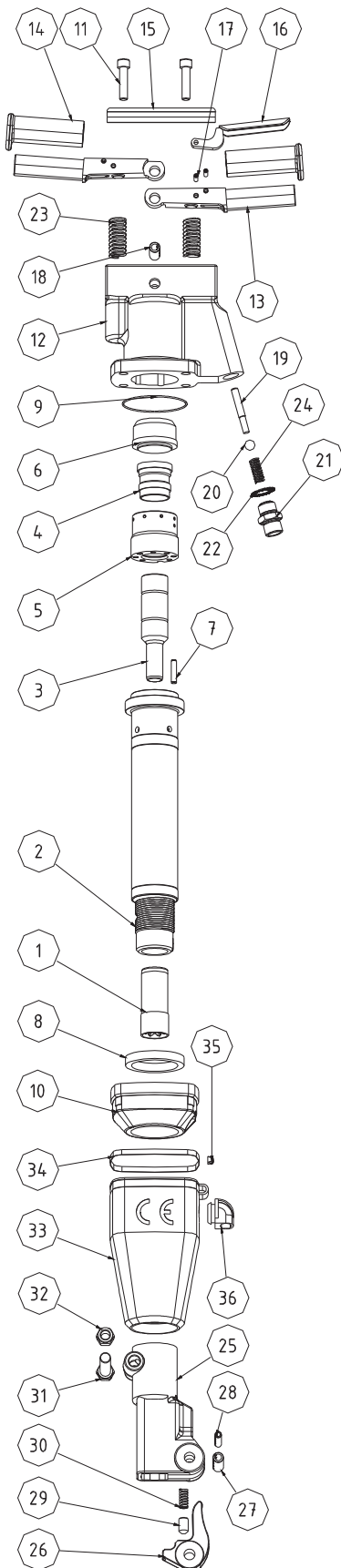

## FK 2020R.94

### Ersatzteilliste



Pos.	Stück	Benennung	Bestell-Nr.	Einsteckende
1	1	Buchse	.52/7486	S 25x108
2	1	Zylinder	.52/2700	
3	1	Kolben	.52/1902	
4	1	Rohrschieber	.52/1904	
5	1	Steuergehäuse	.52/2703	
6	1	Puffer kpl.	.52/2707	
7	1	Stift	304/3632	
8	1	Ring	307/2527	
9	1	O-Ring	307/2478	
10	1	Spannflansch	.52/2514	
11	4	Schraube	308/060450	
12	1	Griff kpl.	.52/2565	
13	2	Griffstück	.52/2557	
14	2	Griffschutz	307/2568	
15	1	Deckel	307/2574	
16	1	Drücker	.52/2558	
17	2	Spannstift	304/3532	
18	1	Spannstift	304/3650	
19	1	Ventil	.52/7532	
20	1	Kugel	307/2088	
21	1	Nippel	306/0228	
22	1	Sicherungsring	304/7165	
23	2	Feder	304/7540	
24	1	Feder	304/7541	
25	1	Haltekappe kpl.	.52/2521	
26	1	Haltehebel	.52/2846	
27	1	Spannstift	304/3654	
28	1	Spannstift	304/3653	
29	1	Druckstift	.52/8115	
30	1	Feder	304/7501	
31	1	Schraube	308/100105	
32	1	Mutter	308/110020	
33	1	Schalldämpfer	307/2572	
34	1	Spannband	.52/2529	
35	1	Spannschloß	306/0489	
36	1	Umlenkung	307/2573	